

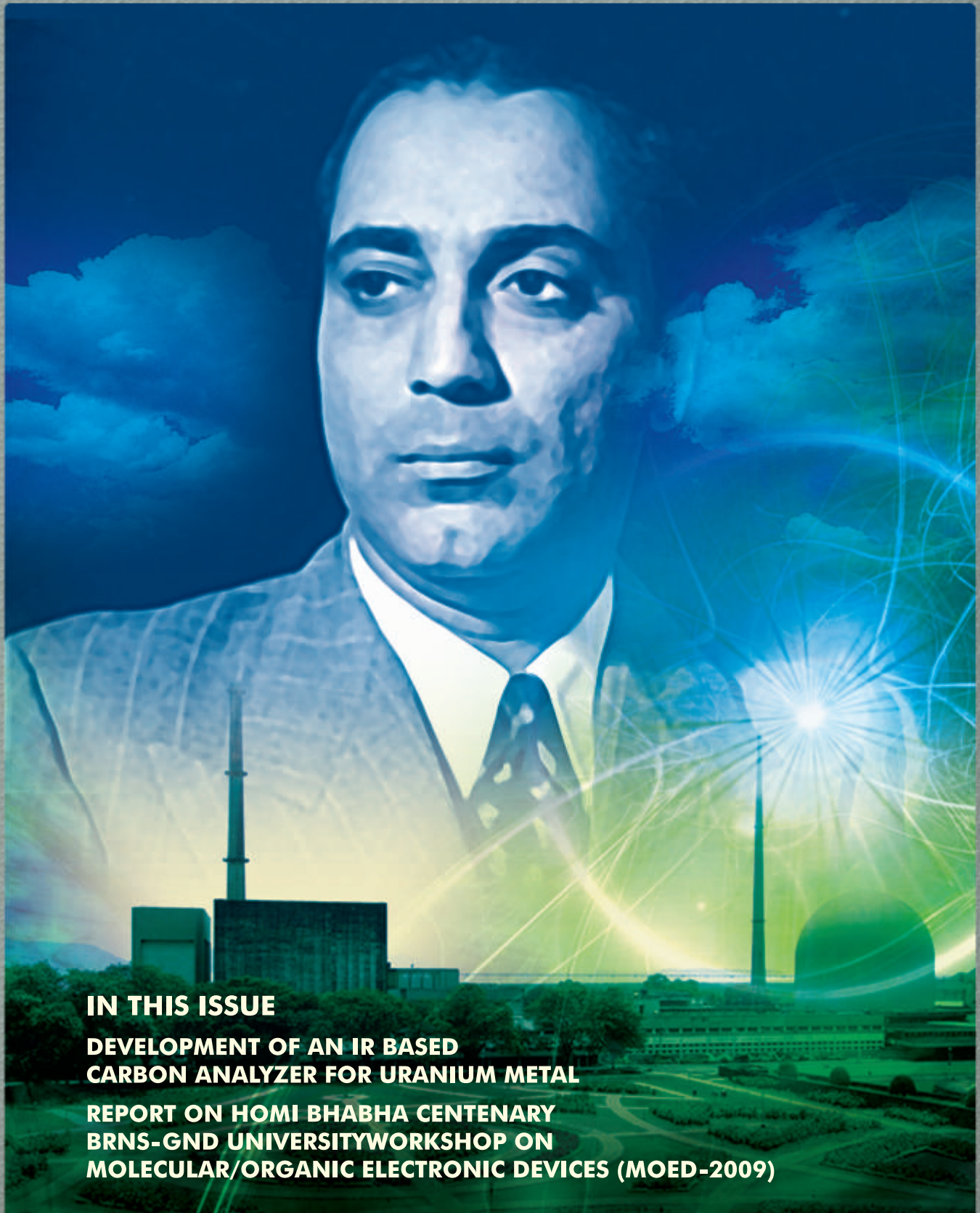

बीएआरसी
न्यूज़लेटर

BARC
NEWSLETTER

ISSUE NO. 311 | DECEMBER 2009



IN THIS ISSUE

**DEVELOPMENT OF AN IR BASED
CARBON ANALYZER FOR URANIUM METAL**

**REPORT ON HOMI BHABHA CENTENARY
BRNS-GND UNIVERSITY WORKSHOP ON
MOLECULAR/ORGANIC ELECTRONIC DEVICES (MOED-2009)**

“ELAC-2010”

4th ISEAC Triennial International Conference on ElectroAnalytical Chemistry and Allied Topics

Under the auspices of Indian Society for ElectroAnalytical Chemistry (ISEAC), the above International Conference would be held at Toshali Sands, Puri, Orissa (www.toshaliresort.com) during March 16-20, 2010. The Conference will be preceded by Short Courses on ElectroAnalytical Chemistry and Materials Characterization on March 14-15, 2010. The Conference would cover recent advances in various ElectroAnalytical Techniques and their applications in Chemistry, Physics, Biology, Material Science, Nuclear Technology etc. Scientific Programme of the Conference would include Invited Talks, Contributed Papers as Posters Presentations, Panel Discussions and Oral Presentations by (M.Sc., Ph.D.) Research Scholars). **Manuscripts of the papers are to be submitted strictly by January 29, 2010.** Further updates about this Conference would be available on www.iseac.org. For any other details, please contact:

Dr. S.K. Aggarwal

Chairman, Organizing Committee
and President, ISEAC
Head, Fuel Chemistry Division
BARC, Mumbai 400 085, INDIA
Tel. No.: 91-22-25593740
Email: skaggr2002@rediffmail.com

Dr (Mrs.) J.V. Kamat

Convener, Organizing Committee
and Treasurer, ISEAC
Fuel Chemistry Division
BARC, Mumbai 400 085, INDIA
Tel. No.: 91-22-25594088 / 25590642
Email: jayshree_kamat@yahoo.co.in

CONTENTS

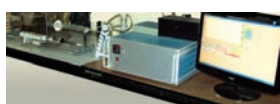

Development of an IR based Carbon Analyzer for Uranium Metal

2



Report on Homi Bhabha Centenary BRNS-GND University Workshop on Molecular/Organic Electronic Devices (MOED-2009)

7



National Symposium on Growth of Detector-grade Single Crystals (NSGDSC-2009): a report

9



Observance of Vigilance Awareness Week in BARC

11



National Theme Meeting "Electrodynamics Experiments with Left Handed Maxwell Systems"

12

भा.प.अ. केंद्र के वैज्ञानिकों को सम्मान
BARC Scientists Honoured

13

URL:<http://www.barc.gov.in>



DR. HOMI BHABHA CENTENARY YEAR

DEVELOPMENT OF AN IR BASED CARBON ANALYZER FOR URANIUM METAL

K. C. Thomas, J. R. Kale, R. G. Dalavi, K. Venkatesh, R. Kameswaran and A.V.R. Reddy

Analytical Chemistry Division

ABSTRACT

A carbon analyzer for measurement of carbon content in the mg kg^{-1} range in uranium metal, has been designed and fabricated. The set-up is based on the measurement of carbon dioxide, liberated subsequent to combustion of carbon, present in the sample in oxygen atmosphere. This analyzer consists of a furnace for sample combustion, a pneumatic flow control section, an IR detector with associated electronic hardware, micro-controller based data acquisition system and dedicated windows-based supporting software for data processing, storage and analysis. The system was standardized, method of analysis was validated and deployed, for routine analysis of carbon in uranium samples.

Introduction

One of the major activities of the Analytical Chemistry Division is the analysis of carbon content in uranium metal samples received from the Quality Assurance Division and the Uranium Extraction Division. For this purpose, an apparatus based on a classical low-pressure method [1] as well as another TCD-based Carbon Analyzer, developed in-house, were used. Low pressure method involves a tedious procedure such as the preparation of acetone-liquid nitrogen slurry. In addition to this, vacuum lines, molecular sieve trap and delicate glassware are also used. On the other hand in the TCD-based analyzer, molecular sieve trap, solenoid valves and helium as carrier gas are used. To provide an improved alternate instrumental technique, a Carbon Analyzer based on IR detection system has been designed, developed and fabricated. This instrumental set-up eliminates several tedious procedures mentioned above as well as it does not require a molecular sieve trap. It uses oxygen for combustion as well as a substitute for the expensive helium carrier gas. The new setup greatly reduces the

analysis time (approximately from 45 minutes to 5 minutes) and uses simplified pneumatic control. The principle of operation is based on the conversion of carbon content in the metal sample into carbon dioxide, by combustion of carbon in the sample in oxygen atmosphere, in a quartz combustion tube and then its detection by using the IR detector. The limit of detection achieved by the system is 10 mg kg^{-1} .

Instrumentation

The instrumental set-up consists of three parts, namely, the pneumatic flow control section (Part 1, Fig.1), the sample furnace (Part 2, Fig.1) and the electronics hardware section consisting of detector electronics and data acquisition system (Part 3, Fig.1).

Pneumatic flow control section

The simplified pneumatic flow control section (Part 1, Fig.1) consists of an oxygen gas regulator, needle valve, flow meter, injection port, dust filter and moisture

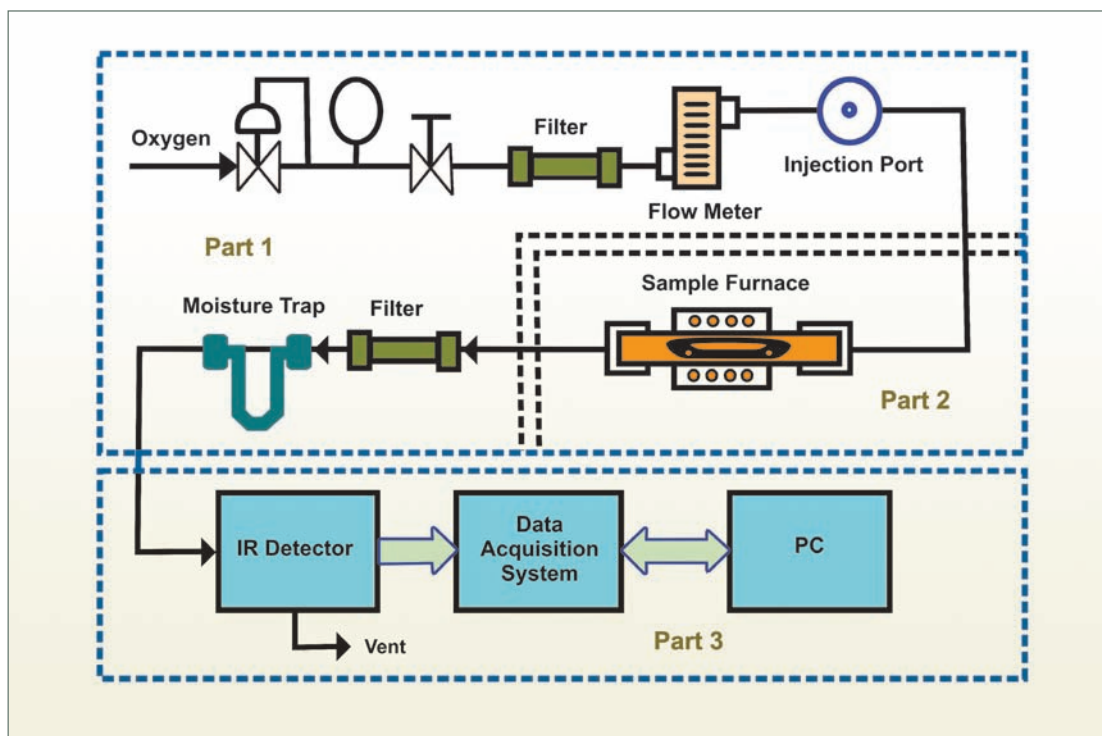

Fig.1: Schematic of the IR-based carbon analyzer

trap. The required oxygen flow rate of 300 mL min^{-1} , set at an inlet pressure of 0.5 kg cm^{-2} , provides the oxygen rich atmosphere for the sample, placed in the quartz combustion tube located inside the sample furnace.

Sample furnace

A resistively-heated, axially movable furnace maintained at $650 \pm 5 \text{ }^\circ\text{C}$ is used for sample combustion (Part 2, Fig.1), as CO_2 is the only product in this temperature region [3]. An axially placed, long (length=100 cm and dia = 4 cm) quartz combustion tube, houses a silica boat in which uranium sample is placed.

Electronics hardware section

Electronic block diagram of the IR-based carbon analyzer is given in Fig. 2. This section includes the IR cell with associated electronics and data acquisition

(length=100 cm and dia = 4 cm) quartz combustion tube, houses a silica boat in which uranium sample is placed. The IR cell is mounted inside a detector oven which is maintained at a constant temperature of $45 \pm 0.5^\circ\text{C}$. The IR cell consists of an IR source, a chopper, an optical filter ($4.26 \mu\text{m}$), a gas cell and an IR detector. The associated electronics include a constant current power supply for the IR source which is a heated nichrome wire maintained at 850°C , a chopper control, a pre-amplifier and a signal conditioning stage. The signal output from the IR cell, proportional to the CO_2 concentration, is fed to the data acquisition hardware. The data acquisition hardware is built around a Philips P89C51RD2 [4] flash micro-controller with an external Analog to Digital Converter (ADC) based on ICL7135 ($4\frac{1}{2}$ digit dual slope integrating type) and an RS-232C based serial interface for PC connectivity. A character-based custom communication protocol is used for system communication.

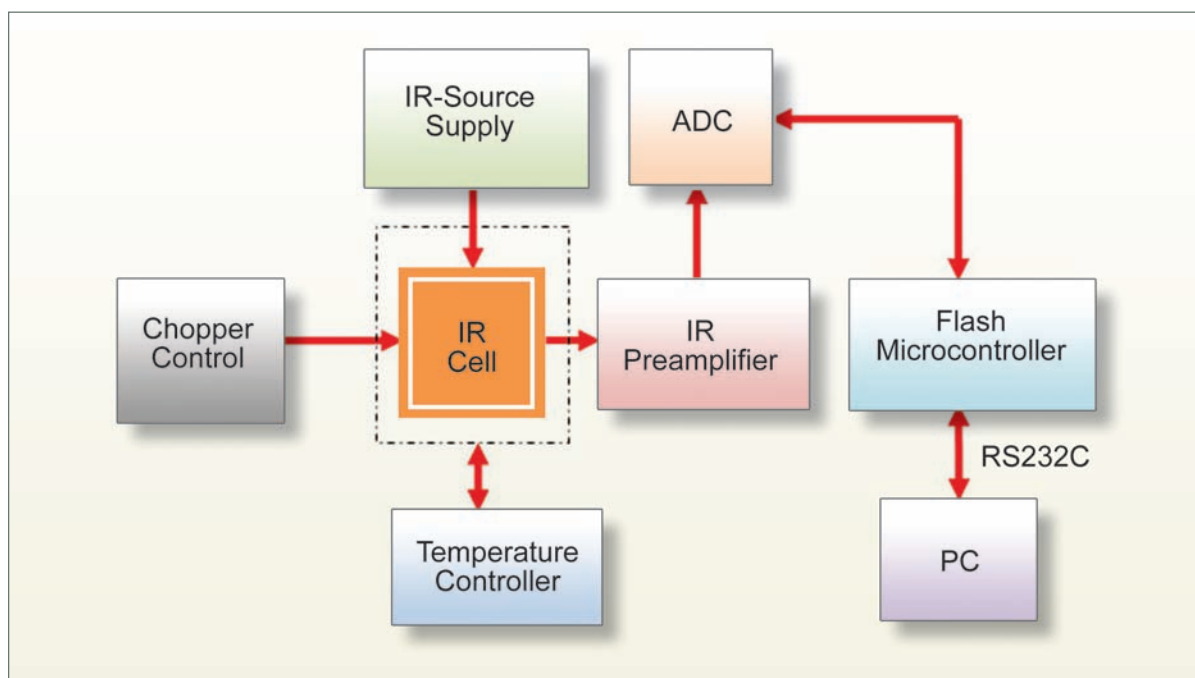

Fig. 2: Electronic block diagram of IR-based Carbon Analyzer

Windows-based software

The Windows-based front-end software has been developed with a Graphical User Interface (GUI) for interactive data acquisition and analysis. It facilitates real time graphical display of the acquired data (IR detector O/P vs. time) with auto-scaling features for both detector signal and time axis, Start and Stop of acquisition, Storage and Retrieval of data files, Peak Identification with information, like peak area, height and time.

System operation

The photograph of the Carbon Analyzer is shown in Fig. 3. The pneumatic flow diagram shown in Part 1, Fig.1 is self-illustrative. The oxygen gas, at a flow rate of 300 mL min^{-1} , set by the corresponding flow controller, flows through the combustion furnace. A long quartz tube, placed in the furnace, with a gas inlet and outlet at opposite ends serves as the combustion chamber. A ceramic boat, in which the

sample to be analyzed, is kept at the centre of the quartz tube. The sample when brought to the hot zone of the furnace, burns immediately due to exothermic reaction between uranium and oxygen with a glow of light. The carbon content in uranium sample undergoes combustion under this condition and the CO_2 released in the process is made to pass through the dust filter and the moisture trap. Then it passes through the IR detector, where the selective absorbance of characteristic IR radiation ($4.26 \mu\text{m}$) by CO_2 takes place. The detector output proportional to the IR absorbance is monitored as a real time graphical display on the PC screen, using the Windows-based supporting software. As the liberated CO_2 reaches the detector, a signal appears and increases with time. It reaches a maximum and then starts decreasing. When it reaches a background level (base line), it indicates that evolution of CO_2 has ceased, as all the carbon present in the sample has been burnt. The integrated signal, in the form of measured peak area, is proportional to the concentration of carbon content in the sample.



Fig. 3: Photograph of the in-house built Carbon Analyzer

Standardization of the system

The system response has been calibrated by injecting known volumes of pure (99.99%) CO₂. The area per microgram of carbon, calculated for CO₂ volume, is obtained from the measured peak area for the injection of known volume of CO₂. Fig. 4 shows the calibration graph obtained for different volumes of injected CO₂ gas, from which carbon content is calculated.

The system reproducibility was found to be within 2%. The method was validated measuring CO₂ released in the combustion chamber, by decomposing a known amount of dried calcium carbonate diluted with dry silica, pre-heated at 500 °C in oxygen flow for 4 hours. Knowing the stoichiometric value of CO₂ released, the area per microgram of carbon was obtained from the analysis of the peak.

Sample analysis

The uranium turnings are cut into small pieces of about 0.2 g and the surface is cleaned by boiling it in 1:4 nitric acid followed by washing with distilled water. The cleaned samples are dried under an IR lamp. An accurately weighed amount is transferred into the ceramic boat and heated at 650°C in an oxygen flow of 300 mL min⁻¹. The evolved CO₂ is measured by recording the IR response. The output as a function of time obtained for a uranium sample is shown in

Fig. 5. The results obtained for uranium samples analyzed using the IR analyzer were compared with those obtained using a Low Pressure method which is an absolute technique, where the amount of carbon in the sample was computed, using gas laws. It is evident from Table 1 that the two methods show good agreement in the carbon values.

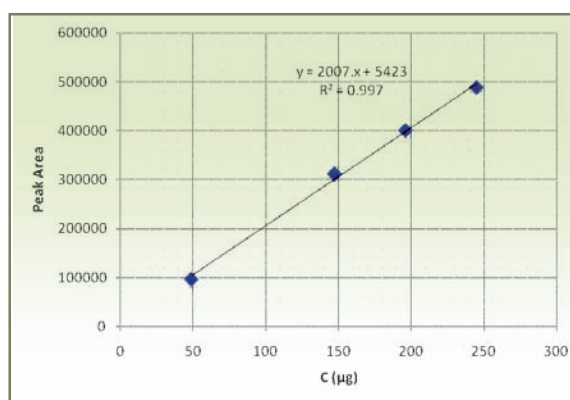

Fig. 4 : Calibration graph

Conclusion

The indigenously developed Carbon Analyzer offers several advantages over the traditionally used Low Pressure Method namely increased sample throughput, ease of operation and elimination of glass wares as well as hazardous chemicals. This analyzer has been deployed for routine analysis of uranium samples for carbon content.



Table 1: Comparison of results

Sample No.	IR analyzer	Low Pressure Method
N-3811	340	330
N-3815	360	400
N-3820	680	650
N-3822	790	790

Acknowledgement

The authors thank the sincere efforts of Ms. Sujata S. Jadhav, Ms. Granthali Kamble and Mr. B.W. Shirsat of Analytical Chemistry Division. The authors are grateful to Dr. P.V. Ravindran, former Head, Electrochemical & Thermal Methods Section of Analytical Chemistry Division, Dr. S.V. Narasimhan, Associate Director

Chemistry Group and Dr. T. Mukherjee, Director Chemistry Group, for their keen interest in this work.

References

1. V.T. Athavale, S.P. Awasthi, N. Krishnamachari, M. Sundaresan and M.S. Varde, *Anal. Chim. Acta*, 35, 1966, 247.
2. K.C. Thomas, J.R. Kale, R.G. Dalavi and P.V. Ravindran, *RACNT-2007* 384-386.
3. Determination of gaseous elements in metals. Ed. Laben M. Melnick, Lynn L. Louis and Ben D. Holt. *Wiley-Interscience Publications* (1974).
4. Phillips Semiconductors 80C51 8-bit Flash microcontroller family data sheet.

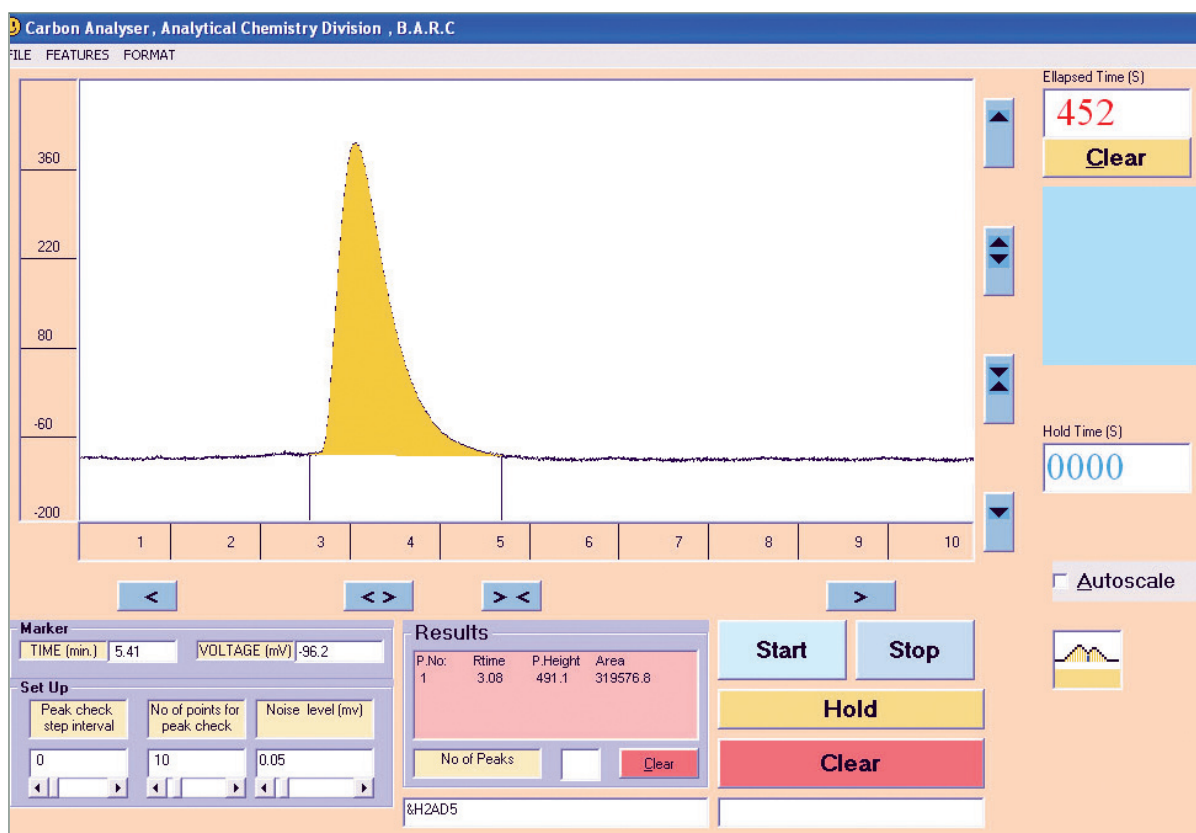

Fig. 5: Output plot with Uranium sample

REPORT ON HOMI BHABHA CENTENARY BRNS-GND UNIVERSITY WORKSHOP ON MOLECULAR/ORGANIC ELECTRONIC DEVICES (MOED-2009)

The Homi Bhabha Centenary BRNS-GND University Workshop on Molecular/Organic Electronic Devices (MOED-2009) was successfully held at the Physics Department, Guru Nanak Dev University, Amritsar and its Conference Centre at Dalhousie, during September 22-25, 2009. The theme of the workshop was discussion of the latest developments in the field of molecular/organic semiconductor based devices.

Dr. J.V. Yakhmi, Associate Director, Physics Group, BARC, inaugurated the workshop. In his inaugural

speech, he pointed out that molecular/organic semiconductors, being lighter, more flexible and less expensive than inorganic counterparts, are fast becoming alternatives to inorganic semiconductors. In addition to this, molecular/organic semiconductors are creating the possibility of new applications, such as printed electronics, smart windows, electronics papers, molecular computers etc. He also emphasized that molecular electronics in future would extend the scaling limits of Si-based microelectronics down to few nanometers.



From left: Prof. R.K. Bedi (Co-convener, MOED-2009), Prof. Ragbir Singh (Dean Academic Affairs, GNDU), Dr. J.V. Yakhmi (Associate Director, Physics Group), Dr. D.K. Aswal (Co-Convener, MOED-2009), Prof. B.S. Bajwa, Head, Physics Department GNDU



DR. HOMI BHABHA CENTENARY YEAR

A total of thirteen eminent speakers from different parts of the world delivered lectures during the workshop. Various issues pertaining to the realization of electronic devices using organic/polymer semiconductors were discussed in detail, during this workshop. Prof. Robert M. Metzger from USA delivered a talk on "Unimolecular Electronics", which dealt with the rectification in the donor-acceptor type single molecules. Dr. Jörg Kröger from Germany discussed on how molecular electronics could be explored with a scanning tunneling microscope. In particular, he discussed the molecular switches and conductance of single-atom contacts. Prof. A.J. Pal from IACS, Kolkata presented a talk on organic/inorganic hybrid systems for electronic memory devices. Prof. (Ms.) Maria Anita Rampi, Italy, discussed how current flowing through metal-molecules-metal junctions could be controlled through an appropriate gating. Prof. K.S. Narayan, JNCAR, Bengaluru, presented a talk dealing with studies of spatially resolved photocurrent from molecular structures, using near-field techniques. Dr. Philippe Leriche, France, explained molecular engineering of conjugated systems to fabricate devices using molecules. Dr. S.K. Gupta, BARC, discussed in detail, about the deposition of molecular monolayers by self-assembly and electrodeposition techniques and their electrical characterization. Prof. Gilles Horowitz, France, delivered a talk on the improvement of the characteristics of organic thin film transistors, by tailoring the interfaces. He also spoke about the commercialization of flexible electronics in the very near future. The talk of Prof. Hideyuki Murata, Japan, dealt with interface engineering of organic electronics devices, using MoO_3 layer. Dr. Maya Lukas, Germany, discussed conductance of self-sustained molecules on metal surfaces, investigated by scanning tunneling microscopy. Prof. Leor Kronik, Israel, presented an excellent theoretical talk dealing with the understanding of the electronic properties at organic/inorganic interfaces from first principles. Dr. Mukesh Joshi, RRCAT, Indore, presented a talk on the physics of polymer-based optoelectronics devices. Dr. D.K. Aswal,

BARC, presented an overview on the development of gas sensors, using both molecular and conducting polymer semiconductor films.

A total of 58 contributory papers were received, out of which 49 participants made Poster presentations. A panel of referees comprising of Prof. Hideyuki Murata, Dr. Maya Lukas and Dr. Jörg Kröger evaluated the poster papers. The following papers were awarded prizes.

- (a) First prize: "*Fabrication of white organic light emitting diodes by controlling the position of the thin layer of red dye in the hole transport layer*" presented by Gayatri Chauhan, National Physical Laboratory, New Delhi.
- (b) Second prize: "*Effect of short chain molecules on metal-molecule-semiconductor junction*", presented by Mohamed Ikram, Karnatak University, Dharwad, Karnataka.
- (c) Third prize: "*Synthesis and characterization of σ - π molecules for hybrid nanoelectronics*" presented by P. Jha, BARC, Mumbai.

During the concluding session, all the three Poster Prize winners made oral presentations of their work. Other participants echoed the view that this workshop not only updated their knowledge about the latest developments in the field of molecular/organic electronics devices, but also helped them to interact directly with pioneers in the field. It was felt that BRNS should organize such workshops regularly.

NATIONAL SYMPOSIUM ON GROWTH OF DETECTOR-GRADE SINGLE CRYSTALS (NSGDSC-2009): A REPORT

The National Symposium on Growth of Detector-grade Single Crystals (NSGDSC-2009) was held during November 19-21, 2009, at the Training School Hostel, Anushaktinagar, Mumbai. Around 125 participants from all over the country attended the symposium. There were 14 invited talks and about 40 contributed papers including 12 oral presentations.

The inaugural function was chaired by Dr. S. Banerjee, Director, BARC with Lt. Gen. (Dr.) V.J. Sundaram as the chief guest. In his welcome address, Dr. Banerjee informed the audience about the genesis of the symposium, and the recent growth of large size, detector-grade, silicon single crystals, in BARC. He also dwelt on the optical crystal growth facility in the centre. Lt. Gen. Sundaram in his speech, emphasized the need to grow high quality single crystals in the country, to meet the demands in the area of defense and space research. Dr. R. Muralidharan, Director, SSPL New Delhi

gave the inaugural lecture on the research presently being carried out on the growth of single crystals at the SSPL.

The invited presentations on the first day at the morning session, were mainly on the facilities of single crystal growth in BARC. Dr. Sadhana Mohan gave an overview of the silicon single crystal growth activity in HWD, BARC and Dr. Sangeeta spoke on the effect of non-stoichiometry, on the growth and optical properties of crystals, grown using the Czochralski technique. The other invited presentations were by senior scientists from different universities and institutes. Prof. H.L. Bhat of IISc, Bengaluru gave a delightful presentation on the growth of cesium-lithium-borate single crystals and factors controlling the growth of good quality crystals. Dr. Bhagavannarayana made a presentation on the characterization of crystals by a high resolution X-ray diffraction technique available at the NPL, New



Lt. Gen. (Dr.) V.J. Sundaram addressing the audience at the inaugural function of the symposium



Delhi. There was a poster session wherein about 20 posters were displayed by the participants of the symposium.

The second day began with oral presentations by researchers followed by an elaborate talk on the Sankaranarayanan-Ramasamy technique, for the unidirectional growth of large size oriented crystals, that was given by one of the inventors of the technique, Prof. P. Ramasamy. Prof. K. Byrappa described the growth of nano-diamond crystals using hydrothermal techniques. Dr. Thamizhavel of TIFR delivered a talk on the growth of new types of intermetallics (magnetic and superconductor materials) employing the high temperature solution technique. Dr. S. Moorthy Babu of the Crystal Growth Centre, Anna University, talked about the growth of InSb crystals, using modified Bridgman method for detector applications. In the last session, four oral presentations were given by the participants. There was also a poster session on the second day and about 20 posters were displayed by the participants of the symposium.

The third and final day began with an oral presentation session and four participants presenting their work. This was followed by an invited talk by Dr. V. Natarajan on the use of piezoelectric crystals, for applications in under water experiments. Dr. D.B. Gadkari explained the detached growth of crystals in a vertical directional solidification technique. Prof. Mihir Joshi of Saurashtra University talked about the doped KDP crystals with improved non-linear optical properties. Dr. Jayavel delivered a talk on the relaxor ferroelectric crystals. Dr. I. Bhowmik delivered an interesting talk describing his work on the growth of lithium tantalate crystals. Thus, a wide spectrum of topics was covered in the invited lectures.

An exhibition was also arranged on this occasion and different crystals such as silicon, cesium-iodide, bismuth-germanate, calcium-fluoride, lithium-tetra-borate, germanium, Nd:YAG etc. grown in BARC were displayed. A few participating business



The BARC stall at an exhibition arranged during the symposium and inaugurated by Mr. T.K. Bera, Associate Director, ChE&T Group, BARC

concerns displayed instruments useful in the processing of single crystals, for studies and device fabrication.

The concluding session was chaired by Dr. G.P. Kothiyal and a detailed discussion took place on the roadmap ahead in the area of single crystal growth in the country. Dr. S.C. Gadkari, the convener of the symposium invited Prof. P. Ramasamy, Prof. K. Byrappa, Dr. R. Jayavel and Dr. V. Natarajan on to the podium for a panel discussion. The decreasing number of crystal growth researchers and a lack of funding from the government agencies were the main topics. Dr. Sadhana Mohan, the Co-convener invited the participants, to collaborate with BARC-projects for common interests through BRNS funding. Further, it was agreed upon, that this kind of symposia are required to increase the awareness of crystal growth among young researchers and increase the quality of research. Dr. A.K. Chauhan, Secretary of the symposium thanked all the participants and delegates for making the symposium a successful event.

OBSERVANCE OF VIGILANCE AWARENESS WEEK IN BARC

As per the Directives of the Central Vigilance Commission, a Vigilance Awareness Week was observed in BARC from 3rd November - 7th November 2009. In addition to taking of the Vigilance pledge by the officers and staff members on 3rd November 2009, various programmes like Essay Competition, Poster Competition and Quiz Competition were organized, as part of the Vigilance Awareness Week. At the concluding session, held on 6th Nov. 2009, an address on "Anti-corruption and Vigilance" was arranged at

BARC, Trombay, by inviting Mr. P. Kandaswamy, IPS, DIG (CBI). The session concluded with distribution of prizes to the winners of the competitions.

The Vigilance Awareness Week, celebrated for the first time in BARC, was well appreciated by the employees/ participants and has generated interest among all employees, on the need to maintain probity and transparency in public life.



At the Concluding session of the Vigilance Awareness Week (from left to right): Mr. S. Goverdhan Rao, Head, Personnel Division, BARC, Mr. P. Kandaswamy, IPS, DIG, CBI, Mumbai, Mr. G.P. Srivastava, Director, E&IG, BARC



DR. HOMI BHABHA CENTENARY YEAR

NATIONAL THEME MEETING ON “ELECTRODYNAMICS EXPERIMENTS WITH LEFT HANDED MAXWELL SYSTEMS”

A one-day National Theme Meeting on Electrodynamics experiments with Left Handed Maxwell (LHM) Systems was held on the 17th August, 2009, at TSH-BARC. The meeting was inaugurated by Dr. Srikumar Banerjee, Director BARC; sponsored by BRNS-DAE; and organized by RRPS, Reactor Control Division, E&I Group, BARC. This new and unique topic was discussed in detail in the theme meeting. The LHM team comprising of Prof. Subal Kar Calcutta University, Ms Tapashree Roy, Research Scholar Calcutta University, Mr. Arijit Mazumder Scientist-SAMEER and Mr. Shantanu Das Scientist BARC, presented a unique LHM Electromagnetic crystal, to Dr. Srikumar Banerjee Director, BARC. It was designed by Labrynth Resonator (LR) and Thin Wires (TW) - to have negative refractive indexed meta-material-LHM (in the range of minus 1 to minus 3 at around 30GHz Ka Band. This meta-material was designed and fabricated for the first time in India, by the LHM team.

Dr. Srikumar Banerjee, Director, BARC, gave an encouraging inaugural talk on this very new science topic; stating the difference between matter and meta-materials (artificially structured), the science of which is still developing and can lead to a possible new theory. The physics of this subject is still at an infant stage. During his welcome address, Mr. G.P. srivastava, Director, E&I Grp., spoke about a memorandum of understanding between BARC, SAMEER & Calcutta University, on a National Programme on Left Handed Maxwell Systems. This basic experimental and theoretical platform envisaged by this MoU, would be useful for developing future LHM components in mid-IR to visible region and in developing several future novel devices, to have “two-handed” Electro-Magnetic interactions, in this very high frequency regime. Left-

handed system is counter-intuitive, which leads to reversal of Snell’s law, leading to negative refractive index-giving concept of ‘plane surface focusing’ beyond diffraction limit. This part, the proposed platform in the joint project development under the MoU; as deliverable, was presented in detail by the LHM team. The reversed Doppler Effect with possibility of RADAR defense applications and reversal of Cherenkov Effect (which has to do with design of suitable detectors and which can make ‘clean beam measurements’ in the particle accelerators), are the future outcomes of this proposed joint endeavour which was presented during detailed deliberations. The topics presented at the theme meeting were, “Introduction to Left Handed Maxwell Systems-and the experiment proposal”, by Mr. Shantanu Das, “Electrodynamics of Left Handed Systems and its applications”, by Prof. Subal Kar, “Design and Fabrication of LHM Structures”, by Tapashree Roy and “Meta-materials: Numerical and Experimental Methods”, by Arijit Mazumder. The detailed deliberations of this ‘new-science’ during the ‘discussion sessions’ opened up several novel ideas for eg. exploring the possibility of active LHM meta-materials, re-thinking regarding physics of square root of product of two negative numbers as negative, 3D-structure fabrication, taking this subject to university students-so as to teach it in ‘popular science way’-to attract students to electrodynamics, re-thinking on physics of conservation laws to explain this counter-intuitive science and research on optical-magnetism, participation of physicists (of optical-community and quantum optics) with electrical engineering team on LHM-theory and experiments. Interestingly, theoretical deliberations on ‘new-quantum prescriptor for momentum’, were proposed by Mr. Shantanu Das, in order to distinguish wave-vector direction opposite

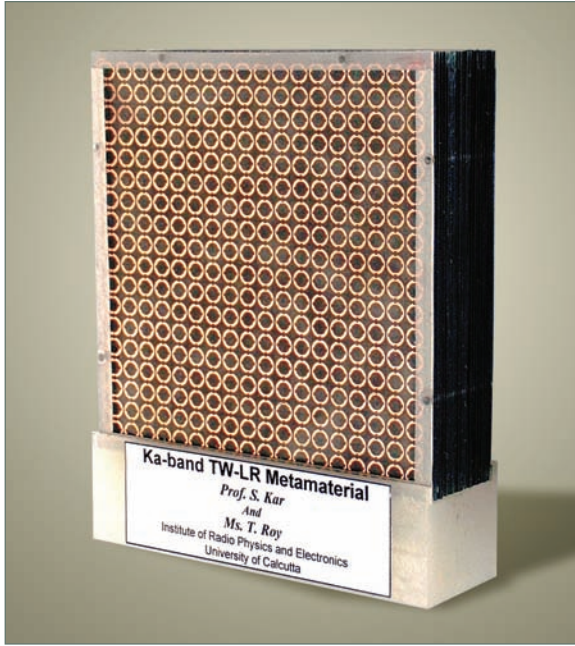

Photograph of the designed and fabricated meta-material crystal of LHM presented to Director, BARC

to Poynting's vector direction-in LHM wave equation, which opens up the possibility of having 'partial' Left Handed Maxwell Systems. That is, material (engineered one) with characteristics of both normal Right Handed Material (RHM) and LHM-meta-materials. This discussion session, on several new-science topics on electrodynamics was guided by Dr. S. K. H. Auluck (ATSS-BARC), Dr. B. N. Jagtap (LPTD-BARC), Prof. Krisna Rai Dastidar (IACS Kolkata), Prof. Deepak Ranjan Poddar (Jadavpur University), Prof. Ananjan Basu (CARE-I.I.T. Delhi), Dr. K. Madhusudhan Reddy (Scientist-ISRO) and Prof. B. N. Mahalley (University of Nagpur).

भा.प.अ. केंद्र के वैज्ञानिकों को सम्मान BARC SCIENTISTS HONOURED



Dr. M.V. Hosur

डॉ. मधुसूदन वी. होसुर, एसएसपीडी, भाभा परमाणु अनुसंधान केंद्र का इन्डियन नैशनल साइन्स अकादमी के सदस्य के रूप में निर्वाचन किया गया है। डॉ. होसुर एक जीव-भौतिक विज्ञानी, एक्स-रे क्रिस्टल विज्ञान को उपकरण बनाकर तीन विमीय संरचनात्मक दृष्टिकोण से जीवाणु का अध्ययन कर रहे हैं।

भाभा परमाणु अनुसंधान केंद्र की ओर से डॉ. होसुर तथा इनके सहकर्मियों ने जीवाणु निष्क्रिय राइबोसोम, जेलोनिन एवं सपोरिन, जिसका विकास कैंसर जैसे रोगों को उपचार वाले कई औषधि से हो सकता है, के संरचनात्मक परमाणु स्तर को निर्धारित किया है। आप सब ने एच आइ वी प्रोटीएस रक्षक, जो एच आइ वी / ए आइडीएस औषधि की आन्विक क्रियाविधि एवं औषधि - प्रतिरोधन - शक्ति की रूपरेखा हेतु विशेष उपयोगी है, का समझाने में प्रमुख योगदान दिया है। डॉ. होसुर राजा रमन्ना सेंटर फॉर एडवांस टेक्नॉलोजी (आरआरसीएटी) में इंडस 2 पर प्रोटीन क्रिस्टल संरचनात्मक विकिरण की स्थापना में भी व्यस्त हैं।

Dr. Madhusoodan V. Hosur, SSPD, BARC has been elected as a Fellow of the Indian National Academy. He is a Biophysicist studying biomolecules from a three dimensional structural perspective, using X-ray crystallography as a tool. He has made significant studies on biomolecules, ranging in size from small nucleotide coenzymes to huge icosahedral viruses. At BARC, Dr. Hosur and his colleagues have determined atomic level structures of ribosome inactivating enzymes, gelonin and saporin, which can be developed



into a variety of drugs to treat cancers. They have made HIV protease, a key target for design of drugs against HIV/AIDS. Dr. Hosur is also involved in the establishment of a protein crystallography beamline on the INDUS-II synchrotron at RRCAT.



Dr. B. N. Pandey

डॉ. बी.एन. पांडे को एशियन असोसियेशन ऑफ रेडियेशन रिसर्च द्वारा प्रायोजित एएआरआर यंग साइंटिस्ट अवार्ड से सम्मानित किया गया। यह अवार्ड उन्हें रेडियेशन रिसर्च के विशय पर महत्वपूर्ण योगदान के लिए दिया गया। यह पुरस्कार इन्हे मई 17-20, 2009 के दौरान सियोल, कोरिया में

आयोजित दूसरे एशियन कॉंग्रेस ऑन रेडियेशन रिसर्च में प्रदान किया गया।

डॉ. पांडे ने 1994-95 में जीव-एवं रेडियो जीव -विज्ञान में ऑरियंटेशन पाठ्यक्रम के 38वें बैच से स्नातकता प्राप्त करके वर्ष 1995 में विकिरण जीव-विज्ञान एवं स्वास्थ्य -विज्ञान प्रभाग में कार्यभार संभाला। इन्होंने वर्ष 2003 में मुंबई विश्वविद्यालय से लाइफ साइंसिज़ में पीएच.डी की डिग्री प्राप्त की। वर्ष 2004-05 में रेडियॉलोजी विभाग न्यू जरसी मेडिकल स्कूल, न्यूयार्क, यूएसए के रेडियेशन रिसर्च प्रभाग में प्रोफेसर ई.आइ. आजम के साथ पोस्ट डाक्टोरल फेलोशिप किया। इस समय आप केन्सर एवं रेडियेशन ब्योलोजी के क्षेत्र के काम में व्यस्त रहें हैं। वर्तमान में आपकी रुचि में इफेक्ट ऑफ लो एन्ड हाई एलईटी रेडियेशन ऑन नॉरमल एन्ड ट्यूमर स्यल्ज़, फॉर सेल्यूलर रेडियो -प्रोटेक्शन एन्ड इंप्रूवरेडियेशन रिसर्चड मेंट ऑफ केन्सर रेडियोथेरेपी शामिल है।

Dr. B.N. Pandey received the 'AARR Young Scientist Award' sponsored by the Asian Association of Radiation Research, for his outstanding contributions in the area of radiation research. The award was conferred on Dr. Pandey during the Second Asian Congress of

Radiation Research, held at Seoul, Korea, during May 17-20, 2009.

Dr. Pandey jointed the Radiation Biology and Health Sciences Division in 1995, after graduating from the 38th Batch of Biology-Radiobiology Orientation Course (1994-95). He received his Ph.D. in Life Sciences from Mumbai University in 2003. He completed his Post Doctoral Fellowship with Prof. E.I. Azzam at the Division of Radiation Research, Department of Radiology, New Jersey Medical School, Newark, USA in 2004-05. Currently, he is working in the field of Cancer and Radiation Biology. His current research interest involves effect of low and high LET radiation on normal and tumour cells, for cellular radio-protection and improvement of cancer radiotherapy.



Dr. B. S. Kademani

डॉ. बी. एस. कडेमनि, वैज्ञानिक सूचना संसाधन प्रभाग, भाभा परमाणु अनुसंधान केंद्र को लाइब्रेरी एन्ड इन्फॉर्मेशन साइन्स के क्षेत्र में प्रमुख योगदान को मान्यता देने हेतु सोसाइटी ऑफ इन्फॉर्मेशन साइन्स के द्वारा "एसआइएस फेलोशिप-2009 अवार्ड" सम्मानित किया गया। यह पुरस्कार इन्हें 9

दिसंबर 2009 को सीएसआइआर-नैशनल केमिकल लेबोरेटरी, पूणे में आयोजित एसआइएस के 26वें वार्षिक सम्मेलन के अवसर पर ओहिओ, यूएसए के केमिकल अबस्ट्रेक्ट सर्विस के उपप्रधान डॉ. क्रेग डब्लू. स्टिफन्स के द्वारा प्रस्तुत किया गया। डॉ. कडेमनि ने वर्ष 1991 में फेकडनफॉर्मेशनसजेन्ट्रम (एफआइज़ड) कार्लश्रुहे, जर्मनी एवं विएन्ना इन्टरनैशनल सेंटर, आस्ट्रिया में "लाइब्रेरी एन्ड साइंटिफिक डॉक्युमेंटेशन" में अंतर्राष्ट्रीय एटोमिक एनर्जी एजन्सी की सदस्यता प्राप्त की। इन्होंने आइएलए-काउला बेस्ट लाइब्रेरियन अवार्ड-2008 भी प्राप्त किया। आप वर्ष 2005 से 2009 के दौरान भारत की ओर से (इन्टरनैशनल फेडरेशन ऑफ लाइब्रेरी एसोसिएशन एन्ड इन्सटिट्यूशंस) आइएफएलए साइन्स एन्ड टेक्नॉलोजी के

अपरिवर्तित सदस्य थे। इस समय आप बॉम्बे साइन्स लाइब्रेरियनस (बीओएसएलए) एसोसिएशन के उपसभापति हैं। अंतर्राष्ट्रीय एवं राष्ट्रीय पत्रिकाओं में इनके 80 से भी अधिक प्रकाशित शोध-पत्र, आठ संपादित पुस्तकें एवं अन्य संग्रह हैं। कई अंतर्राष्ट्रीय एवं राष्ट्रीय व्यावसायिक पत्रिकाओं के आप रेफरी हैं। 30 अक्टूबर 2009 को मुंबई में होमी जहांगीर भाभा की शताब्दी के अवसर पर इनकी लिखी हुई “साइंटोमेट्रिक पोर्ट्रेट ऑफ होमी जहांगीर भाभा: द फादर ऑफ इन्डियन न्युक्लियर रिसर्च प्रोग्राम” नामक पुस्तक का डॉ. श्रीकुमार बेनर्जी, निदेशक, भाभा परमाणु अनुसंधान केंद्र, के द्वारा विमोचन किया गया।

Dr. B. S. Kademani, Scientific Information Resource Division, Bhabha Atomic Research Centre has been awarded the prestigious “SIS Fellowship-2009 Award” by the Society of Information Science(SIS), in recognition of his outstanding contribution to the Library and Information Science field. This award was presented to him by Dr. Craig W. Stephens, Vice President, Chemical Abstracts Service, Ohio, USA on 9th December 2009 on the occasion of 26th Annual Convention of SIS held at CSIR-National Chemical Laboratory, Pune. Dr.Kademani was the recipient of the International Atomic Energy Agency (IAEA) Fellowship in ‘Library and Scientific Documentation’ in 1991 at the Facinformationszentrum (FIZ), Karlsruhe, Germany and Vienna International Centre (VIC), Austria. He was also the recipient of the ILA-Kaula Best Librarian Award-2008. He was also a Standing Committee Member of IFLA’s (International Federation of Library Associations and Institutions) Science and Technology Libraries Section from India for the term 2005-2009. Currently, he is the Vice-Chairman, Bombay Science Librarians’ Association (BOSLA). He has published over 80 research papers in national and International Journals, edited eight books and many compilations. He is also a referee to many national and international professional journals. His book entitled ‘Scientometric Portrait of Homi Jehangir Bhabha: The Father of Indian Nuclear Research Programme’ was released by Dr. Srikumar Banerjee,

Director, Bhabha Atomic Research Centre, Mumbai on 30th October 2009 to mark Homi Bhabha Centenary Year Celebrations.

पथर्थ विज्ञान प्रभाग के संतोष कुमार, अंजन चटर्जी, सी.एस. विश्वनाथम, के. भानुमूर्ति एवं जी.के.डे द्वारा सह लिखित लेख “इलेक्ट्रॉन बीम वेल्डिंग एण्ड लेजर टीआईजी हाइब्रिड वेल्डिंग ऑफ Mo-एलॉय” को दिनांक 4-6 फरवरी, 2009 को मुंबई में आयोजित राष्ट्रीय वेल्डिंग संगोष्ठी, 2008 में सर्वोत्तम प्रस्तुतीकरण हेतु डीएण्डएच सेचेरान पुरस्कार प्रदान किया गया।

The paper “Electron Beam Welding and Laser-TIG Hybrid Welding of Mo-Alloy (TZM)” co-authored by **Santosh Kumar, Anjan Chatterjee, C. S. Viswanadham, K. Bhanumurthy and G. K. Dey of Materials Science Division** won the D&H Secheron Award for the Best Presentation at the National Welding Seminar, 2008 held at Mumbai between February 4-6, 2009.



Mr. Santosh Kumar

श्री संतोष कुमार ने वर्ष 1998 में आईटी-बीएचयू, वाराणसी से धातुकी इंजीनियरी में बी-टेक किया। वे टाटा स्टील में एक वर्ष तक कार्यरत रहे एवं तत्पश्चात भापअ केंद्र के प्रशिक्षण विद्यालय के 43^{वें} बैच से जुड़े। सर्फेस क्लैडिंग एवं / या सर्फेस एलॉइंग द्वारा वेल्डिंग एवं पृष्ठ रूपांतरण हेतु उच्च शक्तिवाले लेजरों के अनुप्रयोग उनके अनुसंधान की अभिरुचि हैं। उन्होंने नॉन-फेरस पथर्थों के वेल्डिंग में सर्वोत्तम लेख हेतु एनडब्ल्यूएस 2002 के दौरान प्रस्तुत अपने लेख के लिए पंथकी पुरस्कार प्राप्त किया। वर्तमान में वे पदार्थ विज्ञान प्रभाग, भापअ केंद्र के लेजर पदार्थ संसाधन प्रभाग में कार्यरत हैं।

Mr. Santosh Kumar completed his B. Tech in Metallurgical Engineering from IT-BHU, Varanasi in



1998. He worked with TATA Steel for one year and subsequently joined the 43rd batch of BARC Training School. His research interests lie in applications of high power lasers for welding and surface modifications of materials by surface cladding and / or surface alloying. He received Panthanki Award for his paper presented at NWS 2002 for the best paper in welding of non-ferrous materials. Presently he is working with Laser Materials Processing Section of Materials Science Division, BARC.



Mr. Anjan Chatterjee

श्री अंजन चॅटर्जी जाधवपुर विश्वविद्यालय, कोलकाता से वर्ष 1981 के बीई (धातुकी) हैं। वे वर्ष 1981 में भापअ केंद्र के प्रशिक्षण विद्यालय के 25वें बैच से जुड़े। वे 1982-1999 तक भापअ केंद्र के विकिरण धातुकी प्रभाग (आरएमडी) में एफबीटीआर ईंधन पिन संविरचन से जुड़े रहे। वर्ष 1999 से वे लेजर

कर्तन एवं लेजर वेल्डिंग में कार्य कर रहे हैं। भुक्तशेष पीएचडब्ल्यूआर ईंधन गुच्छों के लेजर डिसमैंटलिंग हेतु मशीन के डिजाइन एवं संविरचन में उनका योगदान रहा। उन्हें एनडब्ल्यूएस 2002 में पीएचडब्ल्यूआर ईंधन गुच्छों के लेजर डिसमैंटलिंग पर लेख हेतु केसीपी पुरस्कार प्रदान किया गया। वर्तमान में वे पदार्थ विज्ञान प्रभाग के लेजर पदार्थ संसाधन अनुभाग में, समान एवं विपरीत प्रकार के पदार्थों के लेजर-टीआईजी वेल्डिंग पर कार्य कर रहे हैं।

Mr. Anjan Chatterjee is BE (Met) from Jadavpur University, Kolkata in 1981. He joined the 25th batch of BARC Training School in 1981. During 1982-1999 he was associated with FBTR fuel pin fabrication in Radio Metallurgy Division (RMD) of BARC. Since 1999 he is working in laser cutting and laser welding. He contributed to the design and fabrication of a machine for laser dismantling of spent PHWR fuel bundles. He was awarded KCP award for his paper on

laser dismantling of PHWR fuel bundles in NWS 2002. Presently he is working in Laser Materials Processing Section of Materials Science Division. He is working on Laser-TIG hybrid welding of similar and dissimilar materials.



Mr. J.S. Visvanadham

श्री जेबोलू सुब्रमन्य विश्वनाथम ने आईआईटी, मद्रास से अपनी भौतिकी में एम.एससी करने के पश्चात भापअ केंद्र प्रशिक्षण विद्यालय के 24वें बैच से स्नातक की उपाधि प्राप्त की। वे टीआईएफआर, मुंबई से साफ्टवेयर प्रौद्योगिकी में स्नातकोत्तर प्रमाण-पत्र धारक

भी हैं। उनके अनुसंधान की अभिरुचि में नाभिकीय पदार्थों के संसाधन हेतु औद्योगिक लेजरों का अनुप्रयोग, एवं लेजर तथा न्यूट्रॉन किरणन के अंतर्गत पदार्थों का कंप्यूटर प्रतिरूपण शामिल है। वर्तमान में वे पदार्थ विज्ञान प्रभाग के लेजर पदार्थ संसाधन अनुभाग में कार्यरत हैं।

Mr. Chebolu Subrahmanya Viswanadham graduated from the 24th Batch of BARC Training School in Physics after an M.Sc. degree from IIT Madras. He also holds a Postgraduate Certificate in Software Technology from TIFR, Mumbai. His research interests include the application of industrial lasers to process nuclear materials, and computer modelling of materials' behaviour under laser and neutron irradiation. Currently he is with the Laser Materials Processing Section of the Materials Science Division.

डॉ. के. भानुमूर्ति भापअ केंद्र प्रशिक्षण विद्यालय के 24वें बैच से जुड़े। उनके अनुसंधान की अभिरुचि में धातु एवं मिश्र धातुओं में इंटरडिफ्यूजन अध्ययन, समान एवं विपरीत प्रकार के पदार्थ का प्रगत ठोस अवस्था प्रक्रिया से जोड़ना, घर्षण स्टर वेल्डिंग, पदार्थ अभिलक्षणन, कला चित्र अध्ययन एवं मूल्यांकन शामिल हैं। वर्तमान में वे अध्यक्ष, एसआईआईआरडी हैं।



Dr. K. Bhanumurthy

Dr. K. Bhanumurthy joined the 24th batch of BARC Training School. His research interest includes interdiffusion studies in metals and alloys, similar and dissimilar materials joining using advanced solid state processes, friction stir welding, materials characterization, phase diagrams study and evaluation. Presently he is Head of the Scientific Information Resource Divn. BARC.



Dr. Gautam Kumar Dey

डॉ. गौतम कुमार डे ने वर्ष 1979 में प्रौद्योगिकी संस्था, बनारस हिंदू विश्वविद्यालय से धात्विक इंजीनियरी में अपनी बीटेक की उपाधि प्राप्त की। वे भापअ केंद्र प्रशिक्षण विद्यालय के 23वें बैच में शामिल हुए एवं अपने विषय में प्रथम स्थान प्राप्त करने के लिए उन्हें होमी भाभा पुरस्कार प्रथम किया गया था। प्रशिक्षण पूरा करने के पश्चात उन्होंने भापअ केंद्र के धातुकी प्रभाग में कार्यग्रहण किया। उन्होंने वर्ष 1988 में बनारस हिंदू विश्वविद्यालय से अपनी पीएचडी की उपाधि प्राप्त की। वे वर्ष 1994 से 1996 तक सिनसिनाटी विश्वविद्यालय के पोस्ट डॉक्टरल सदस्य थे। वे ओसाका, जापान के विश्वविद्यालय एवं इन्स्टिट्यूट फोर फेस्टकोरपरफोस्वांग (IFF), जूलिच, जर्मनी के विजिटिंग वैज्ञानिक रहे। उन्होंने अपने वैज्ञानिक योगदान के लिए अनेक पुरस्कार प्राप्त किए। इनमें से भारतीय राष्ट्रीय विज्ञान अकादमी का युवा वैज्ञानिक पुरस्कार (1989), इस्पात एवं खनिज मंत्रालय द्वारा युवा धातु विज्ञान पुरस्कार (1989), भारतीय पदार्थ अनुसंधान संस्था द्वारा युवा धातु विज्ञान पुरस्कार (2001) एवं इस्तात मंत्रालय द्वारा वर्ष के धातुकीविदपुरस्कार (2003) एवं वास्विक पुरस्कार का उल्लेख किया जा सकता है। वे भारत के राष्ट्रीय इंजीनियरी अकादमी (INAE) भारतीय विज्ञान अकादमी (IAS) एवं भारतीय इलेक्ट्रान

सूक्ष्मदर्शी संस्था के सदस्य हैं। वे भारतीय धातु संस्था के ट्रान्जैक्शन के सह संपादक हैं। उनके अनुसंधान की अभिरुचि है जर्कोनियम एवं निकल आधारित मिश्रधातुओं में कला परिवर्तन, अक्रिस्टलीय मिश्रधातु, तीव्र ठोसीकृत क्रिस्टलीन एवं अर्ध क्रिस्टलीन मिश्रधातु, इलेक्ट्रान सूक्ष्मदर्शी, एवं थेष अभिलक्षणन तथा उच्च वियोजन इलेक्ट्रान सूक्ष्मदर्शी। उन्हें 200 से भी अधिक वैज्ञानिक प्रकाशन का श्रेय प्राप्त है। उन्हें होमी भाभा राष्ट्रीय संस्था में प्रोफेसर के रूप में नामोद्दिष्ट किया गया है एवं वर्तमान में पथर्थ विज्ञान प्रभाग, भापअ केंद्र के अध्यक्ष हैं।

Dr. Gautam Kumar Dey obtained his B. Tech in Metallurgical Engineering in 1979 from the Institute of Technology, Banaras Hindu University. He joined the 23rd batch of BARC Training School and was awarded the Homi Bhabha prize for standing first in his discipline. On completion of training, he joined Metallurgy Division of BARC. He obtained his Ph. D degree from Banaras Hindu University in 1988. He was a postdoctoral fellow at University of Cincinnati from 1994 to 1996. He has been Visiting Scientists at University of Osaka, Japan and Institut fur Festkorperforschung (IFF), Juelich, Germany. He has won several awards for his scientific contributions. Of these mention can be made of the Young Scientist award of Indian National Science Academy (1989), Young Metallurgist Award given by Ministry of Steel and Mines (1989), MRSI Medal given by Materials Research Society of India (2001) and Metallurgist of the year award given by Ministry of Steel (2003) and the Vasvik Award. He is a fellow of the Indian National Academy of Engineering (INAE), Indian Academy of Science (IAS) and Electron Microscopy Society of India (EMSI). He is associate editor of Transactions of the Indian Institute of Metals. Areas of his research interest are Phase Transformation in Zirconium and Nickel Base Alloys, Amorphous Alloys, Rapidly Solidified Crystalline and Quasicrystalline Alloys, Electron Microscopy and Defect Characterization and High Resolution Electron Microscopy. He has more than 200 scientific publications to his credit. He has been designated a Professor in the Homi Bhabha National Institute and is currently the Head of Materials Science Division, BARC.



Sketch by Dr. Homi J. Bhabha

Edited & Published by:

Dr. K. Bhanumurthy

Head, Scientific Information Resource Division,
Bhabha Atomic Research Centre, Trombay, Mumbai 400 085, India.

Editorial Management: Dr. (Ms.) S. C. Deokattey,

Computer Graphics & Layout: Mr. B. N. Chavan, SIRD, BARC

BARC Newsletter is also available at

URL: <http://www.barc.gov.in>